

# PK tools and blades instruction

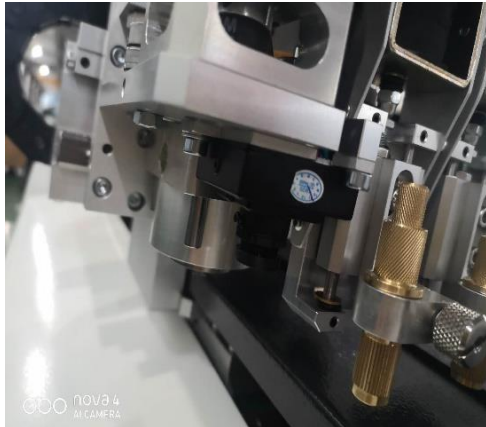

# 1. TW tools.

(1)The first-generation:



The blades (first-generation):



Model and material number:

1.5mm "U" circlip blade	1.5mm circular circlip blade
NUM : 1.20.18.0000244	NUM:1.20.18.0000244

Suitable cutting material: self-adhesive paper, 3M, reflecting film, cardboard. The maximum weight of cutting material is 350g.

(2)The second-generation:

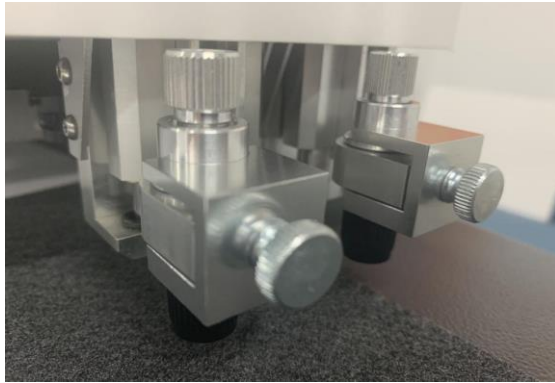

The blades (second-generation):



Model and material number:

1.5mm E15-02	1.0mm E15-01
1.20.18.0000256	1.20.18.0000255

Suitable cutting material: self-adhesive paper, 3M, reflecting film. cardboard. The maximum weight of cutting material is 350g.

## Blade drawing

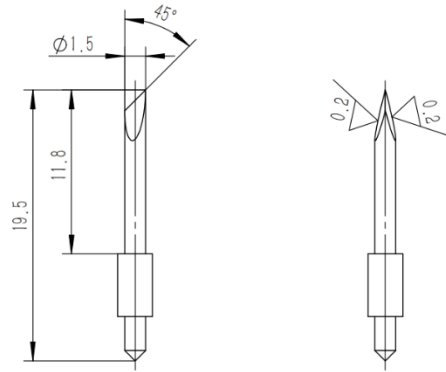

## 2. Creasing tool.

### Blade drawing

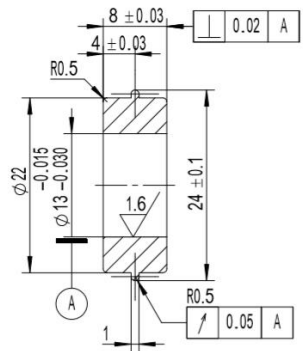
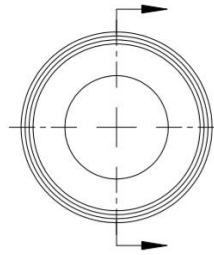

Suitable cutting material: Cardboard and corrugated paper.

### 3. EOT tool.

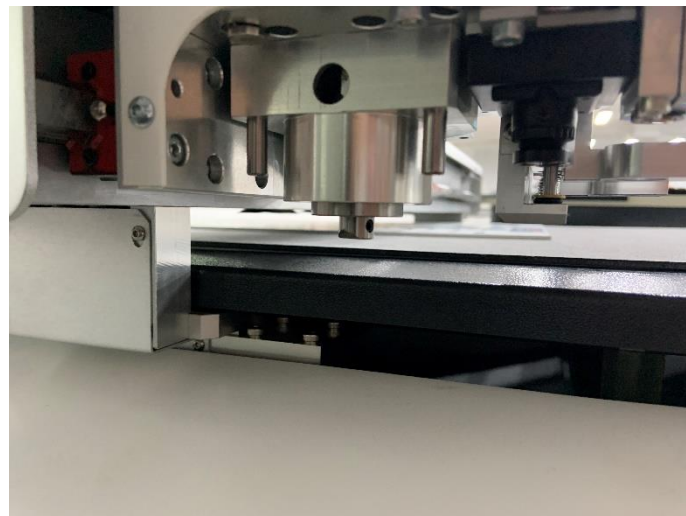

Model and material number:

E19-3(30° Blade of EOT)	E19-2(10° Blade of EOT)
1.20.18.0000242	1.20.18.0000241

Suitable cutting material: cardboard, corrugated paper, vertical, corrugated board, KT board, ect. The maximum thickness of cutting material is within 6 mm.

## Blade drawing

(1) The knife angle is 30 degrees

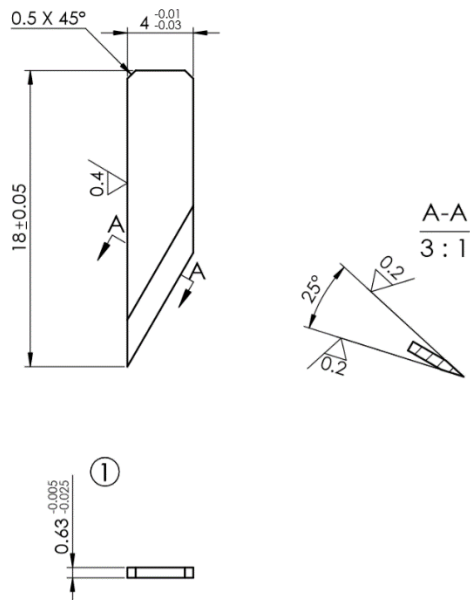

(2) The knife angle is 10 degrees

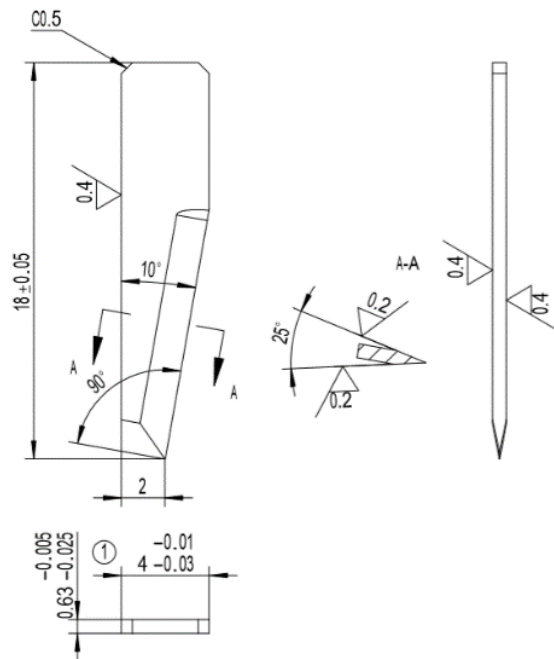

### Note:

1. All tool depths need to be adjusted manually.
2. TW tools can realize half cutting and full cutting by adjusting the depth of cutter. How to adjust can refer to the relevant video.